

DC 2-Wire (PUR Cable/Self-diagnosis Output), AC 2-Wire and AC/DC 2-Wire

E2E-X2Y1 2M

Proximity Sensor, Cylinder type (with screw), Sensing distance: 2 mm, Shielded, AC 2-wire, NO, Pre-wired model, Standard PVC cable (oil resistant), 2 m



Image

Sensing head size	M12
Type	Cylinder type (with screw), Shielded
Power source	AC 2-wire models
Sensing distance	2 mm \pm 10%
Setting distance	0 to 1.6 mm
Operation mode	NO

Ratings/Performance

As of September 4, 2025

Sensing head size	M12
Type	Cylinder type (with screw), Shielded
Power source	AC 2-wire models
Sensing distance	2 mm \pm 10%
Setting distance	0 to 1.6 mm
Differential distance	10% max. of sensing distance
Sensing object	Ferrous metal (Sensitivity lowers with non-ferrous metals.)
Standard sensing object	Iron 12 x 12 x 1 mm
Response frequency	25 Hz
Power supply voltage	24 to 240 VAC
Operating voltage range	20 to 264 VAC
Leakage current	1.7 mA max.
Control output (Switching capacity)	5 to 200 mA
Indicator	Operation indicator (red)
Operation mode	NO
Protective circuit	Surge suppressor
Ambient temperature (Operating)	-40 to 85 °C (with no freezing or condensation)
Ambient temperature (Storage)	-40 to 85 °C (with no freezing or condensation)
Ambient humidity (Operating)	35 to 95 % (with no condensation)
Ambient humidity (Storage)	35 to 95 % (with no condensation)
Temperature influence	\pm 15% max. of sensing distance at 23 °C in the temperature range of -40 to 85 °C \pm 10% max. of sensing distance at 23 °C in the temperature range of -25 to 70 °C
Voltage influence	\pm 1% max. of sensing distance at rated voltage in the rated voltage \pm 15% range
Insulation resistance	Between charged parts and the case: 50 M Ω min. at 500 VDC

Dielectric strength	Between charged parts and the case: 4,000 VAC 50/60 Hz 1 min
Vibration resistance	Destruction: 10 to 55 Hz, 1.5 mm double amplitude each in X, Y, and Z directions for 2 h
Shock resistance	Destruction: 1000 m/s ² 10 times each in X, Y, and Z directions
Degree of protection	IEC: IP67 Company standard: Oil-proof
Connection method	Pre-wired models (2 m)
Weight	Package: Approx. 70 g
Material	Case: Brass nickel plating Sensing surface: Polybutylene terephthalate (PBT) Cable: PVC Clamping nuts: Brass nickel plating Toothed washers: Iron zinc plating
Accessories	Instruction manual, Clamping nuts, Toothed washers

As of September 4, 2025

Dimensions

As of September 4, 2025

Dimensions

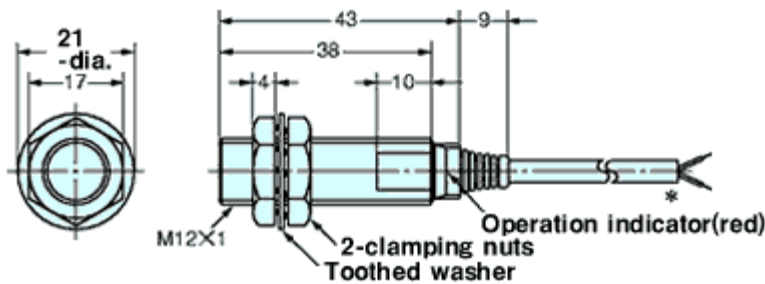

* 4-dia. vinyl-insulated round cable with 2 conductors
(Conductor cross section: 0.3 mm², Insulator diameter: 1.3 mm)
Standard length: 2m
The cable can be extended (separate metal conduit) up to 200 m.

As of September 4, 2025

Output circuit

As of September 4, 2025

Output circuit

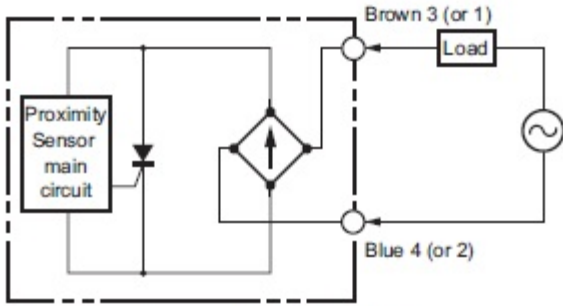

Note: For Connector Models, the connection between pins 3 and 4 uses an NO contact, and the connection between pins 1 and 2 uses an NC contact.

Timing chart

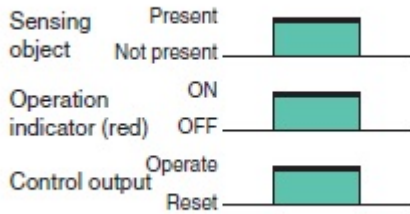

As of September 4, 2025

Mutual interference

As of September 4, 2025

Mutual interference

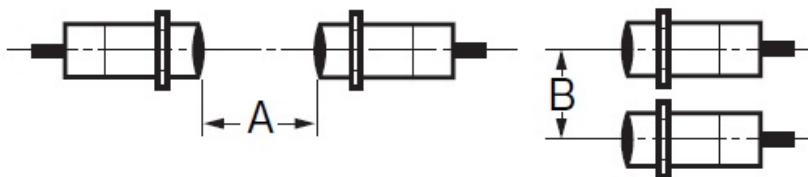

A: 30 mm min., B: 20 mm min.

As of September 4, 2025

Effects of surrounding metals

As of September 4, 2025

Effects of surrounding metals

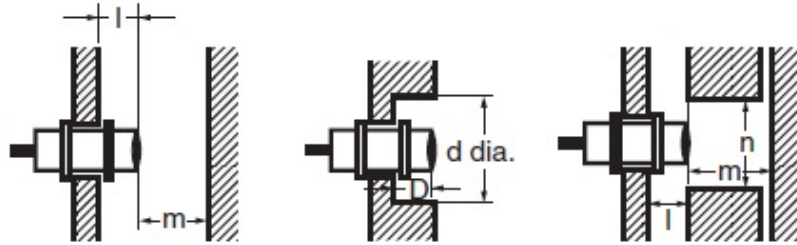

l: 0 mm min., dia. d: 12 mm min., D: 0 mm min., m: 8 mm min., n: 18 mm min.

As of September 4, 2025

Characteristic chart

As of September 4, 2025

Sensing distance vs. size and material of sensing object

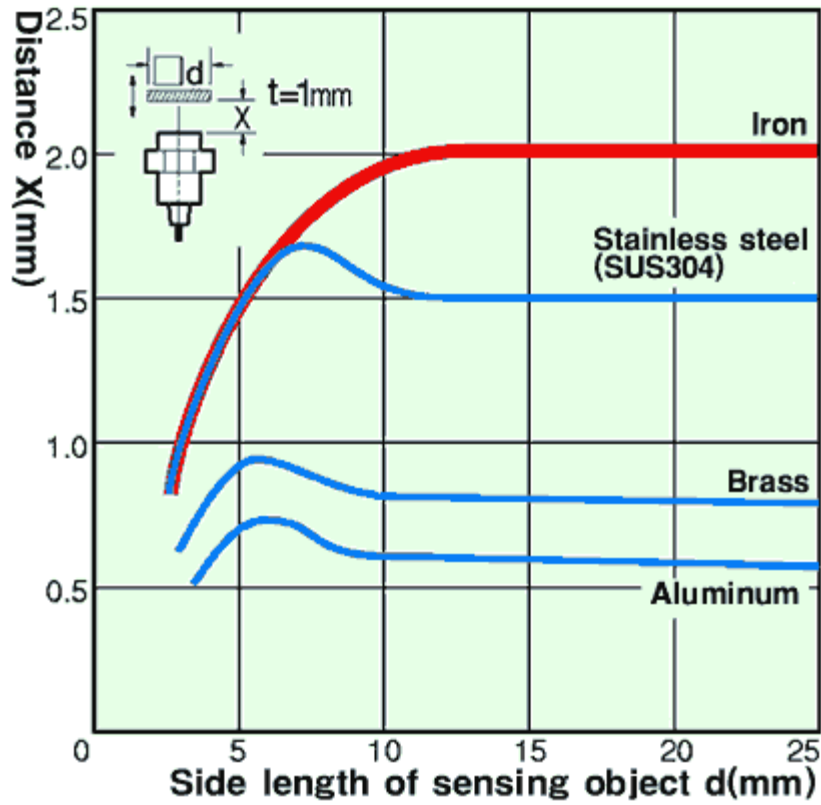

Sensing range

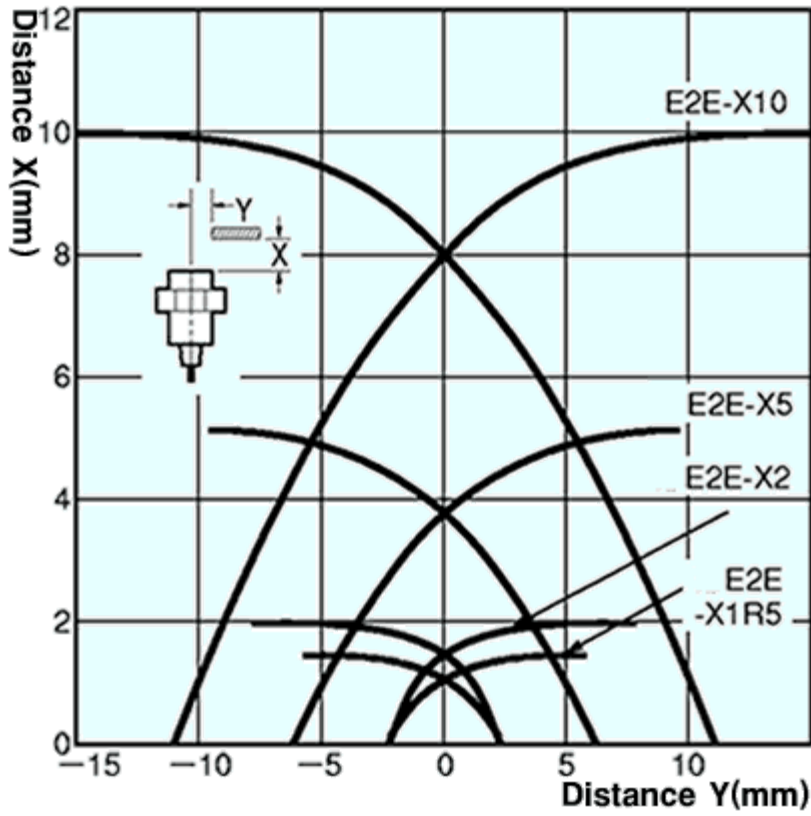

Leakage current

E2E-X□Y□

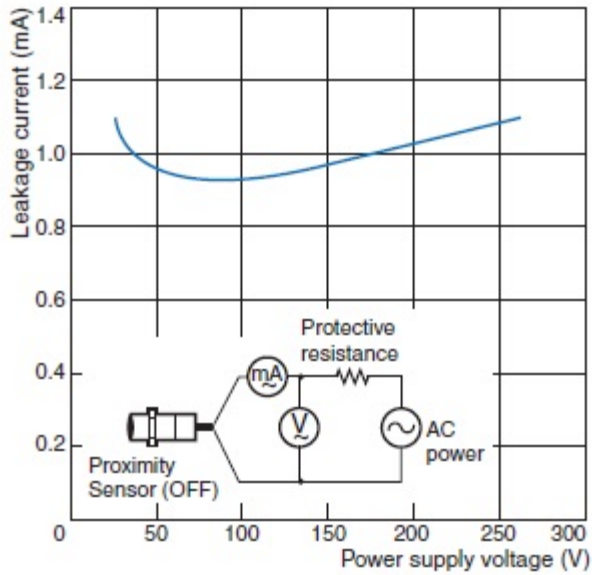

Residual voltage

E2E-X□Y□ at 24 VAC

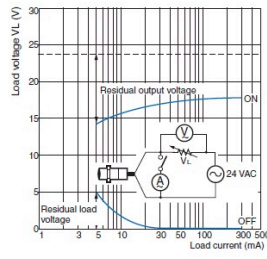

E2E-X□Y□ at 100 VAC

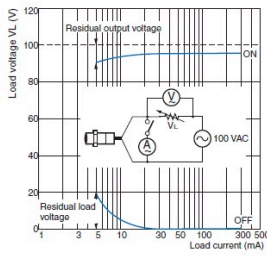

E2E-X□Y□ at 200 VAC

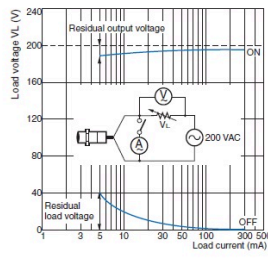

As of September 4, 2025